

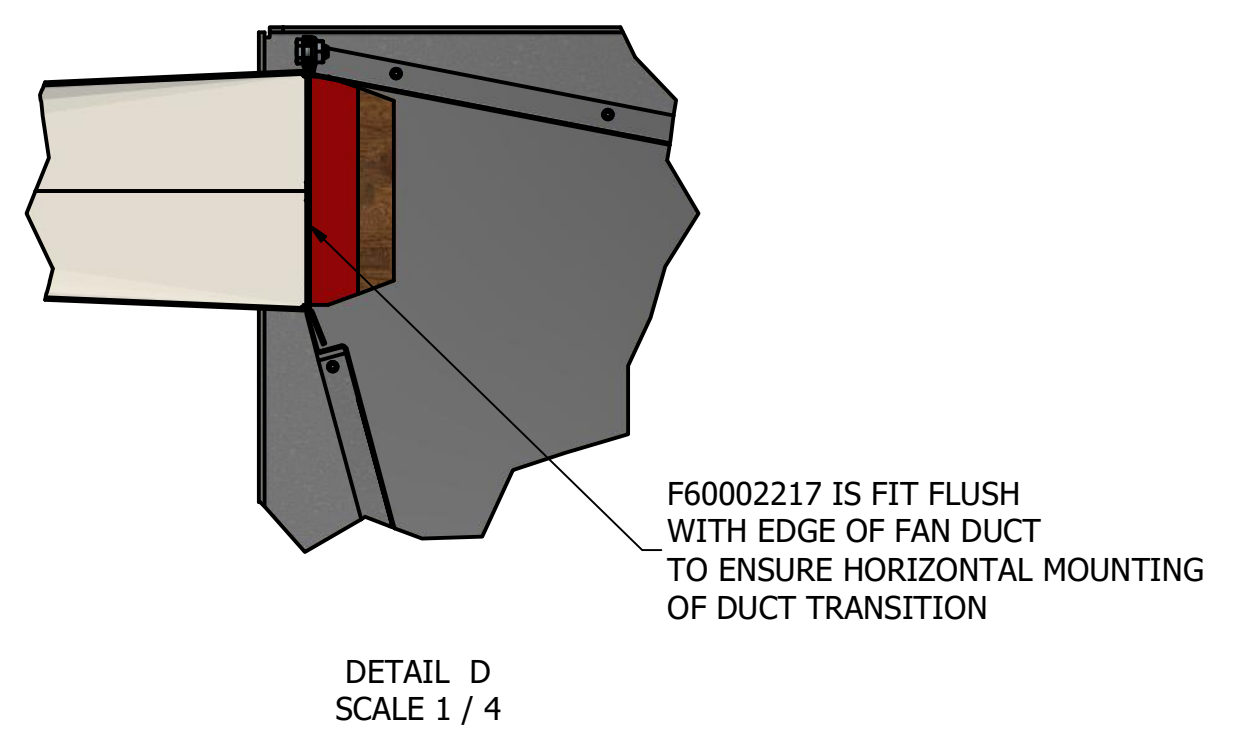

REVISION HISTORY				
REV	ECN	DESCRIPTION	DATE	APPROVED
A	F120019	RELEASED	4/25/2012	DCCLARK
B	F130059	ADDED INFORMATION ON FAN DUCT TRANSITION AND AUGER	4/12/2013	DCCLARK
C	F140154	CHANGED NOTE, LIFTING WITH AUGER	9/26/2014	DCCLARK
D	F150001	CHANGED STANDARD AUGER F60009200 STEEL AUGER TO F60009204 POLY AUGER	2/9/2015	DCCLARK
E	F180059	SHEETS 6 & 7 ADDED	7/9/2018	samelching

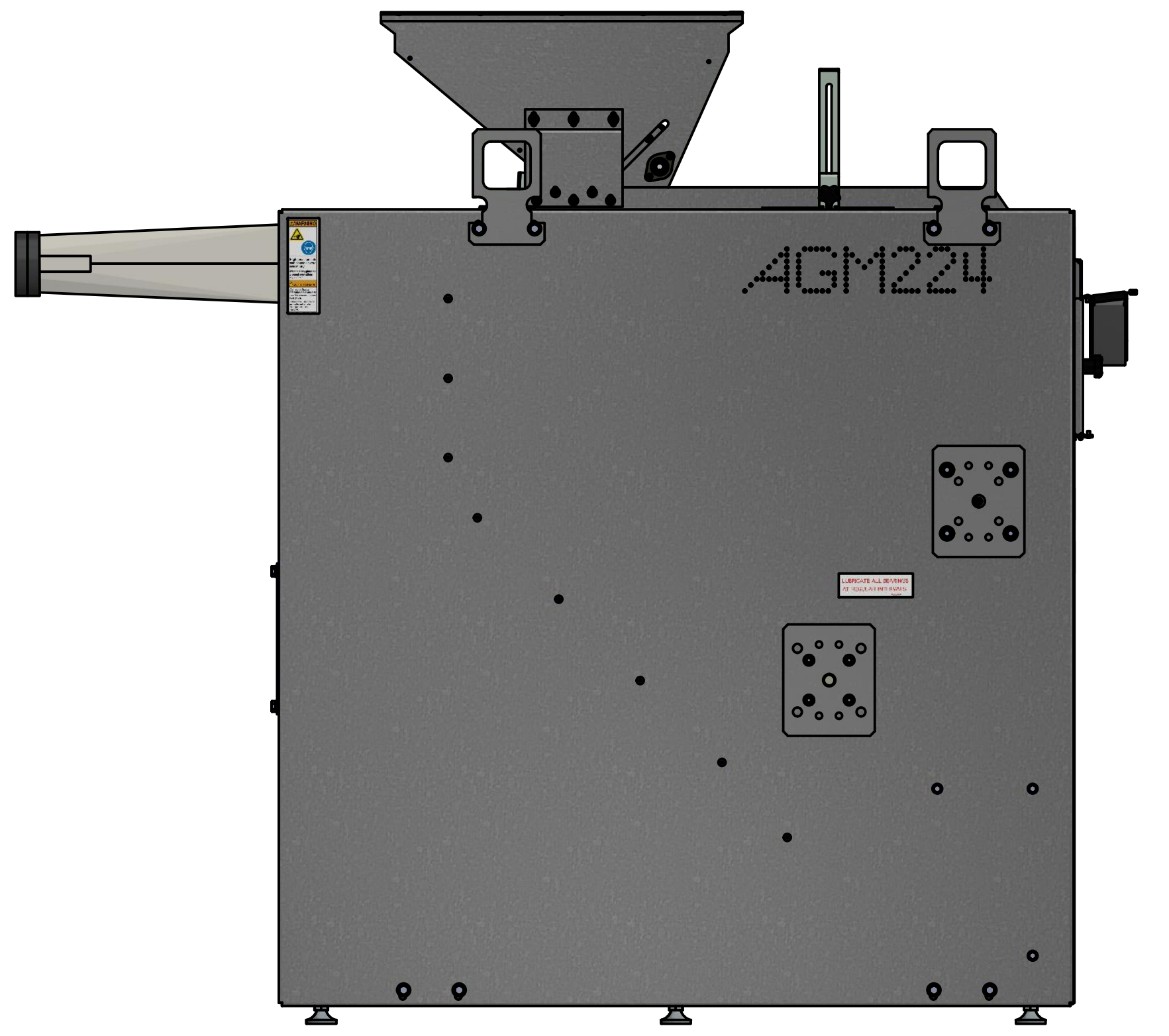
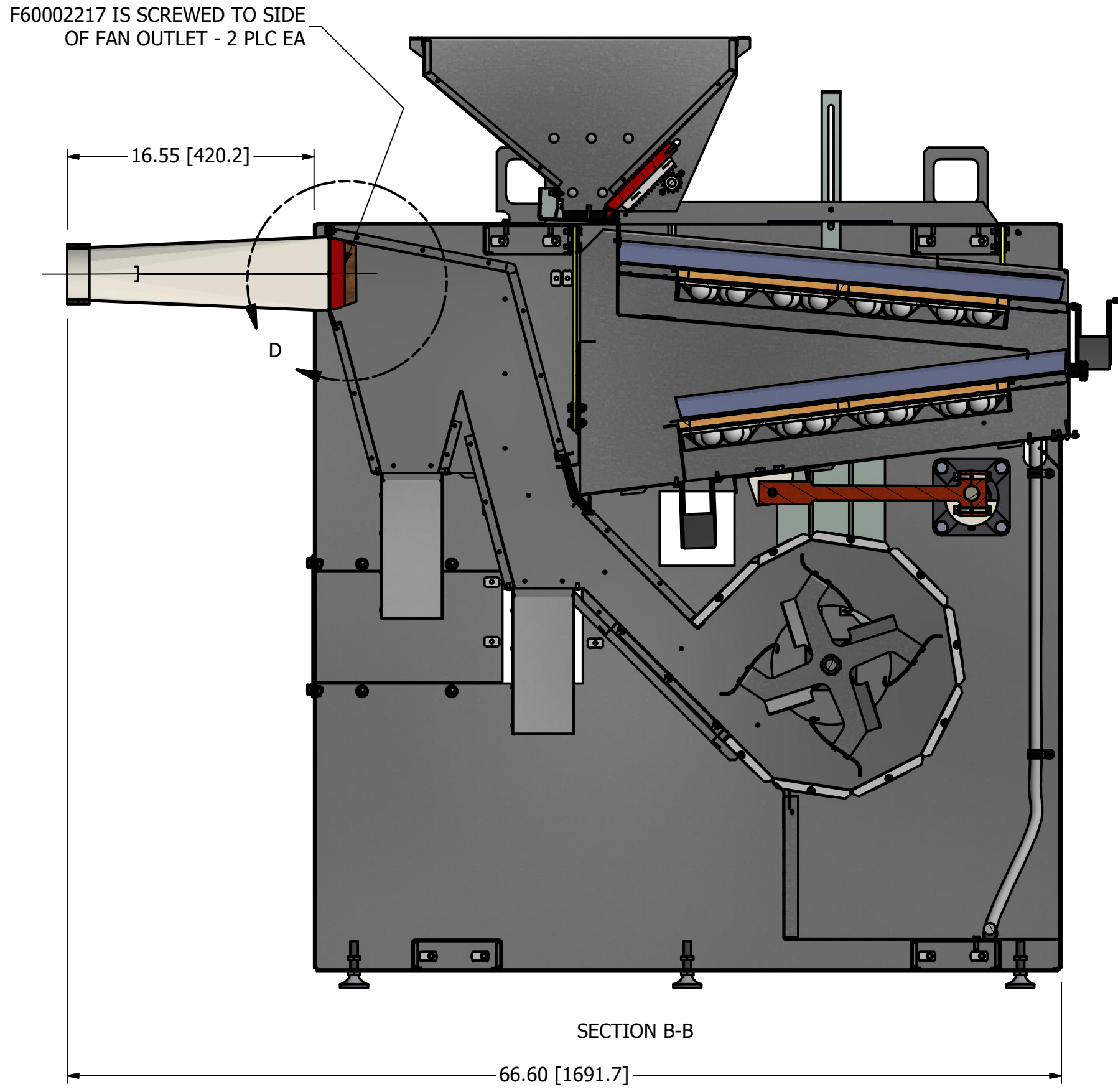
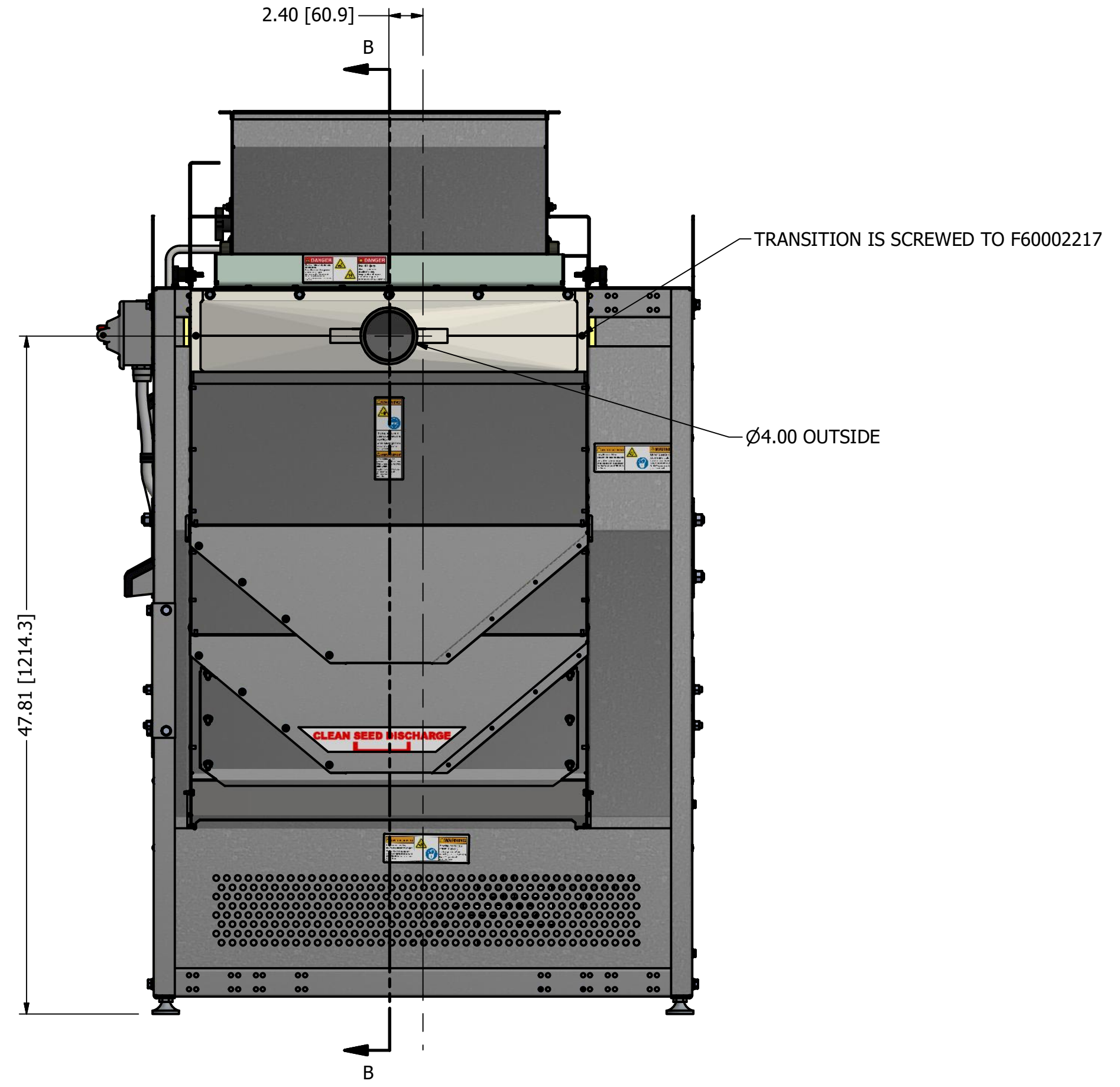

- NOTES:
- DO NOT SCALE FROM DRAWING.
 - ITEMS DENOTED BY A ASTERISK * ARE LINE ITEMS
 - LEVELING FEET NOT SHIPPED ATTACHED. USE OF LEVELING FEET OPTIONAL.
 - **MACHINE MUST BE LEVELED FOR OPTIMAL PERFORMANCE**
 - **FASTENING TO FLOOR RECOMMENDED WITH BAGGING AUGER**
 - APPLICATION OF FEET AFFECTS OVERALL HEIGHT OF MACHINE.
 - ALTERNATIVE UNITS [X.X] IN MILLIMETERS.
 - MACHINE WEIGHT LESS STAND, AUGER, AND SURGE HOPPER: 750 LBS / 340 KG.
 - 0.50" [12.7] TOTAL THROW, SHOE.
 - FAN AIR DISCHARGE: 1440 CFM / 40.5 CMM MAXIMUM.
 - SIX 1/2-13 GRADE 5 BOLTS RECOMMENDED TO LAG FRAME THRU FLOOR JOISTS.
 - RECOMMENDED MAINTENANCE CLEARANCE FROM FRAME: 36.00" [915] AT FRONT & SIDES, 12.00" [305] AT REAR.
 - FUSED DISCONNECT REQUIRED PRIOR TO MACHINE MOUNTED SWITCH BOX.
 - MOTOR WITH SWITCH: 3/4 HP 1Ø 60 HZ 115/208/230 VOLT TEFC, MANUAL THERMAL RESET, FULL LOAD AMPS 8.2/5.4/4.1
 - MOTOR WITH SWITCH: 3/4 HP 1Ø 50 HZ 110/220 VOLT TEFC, MANUAL THERMAL RESET, FULL LOAD AMPS 11.8/5.9.
 - MOTOR WITHOUT SWITCH: 3/4 HP 1Ø 60 HZ 115/230 VOLT XPFC, U.L. & CSA APPROVED CLASS I, GROUP D, CLASS II, GROUP F & G, T4, FULL LOAD AMPS 10.6/5.3.
 - MOTOR WITHOUT SWITCH: 3/4 HP 3Ø 60 HZ 208/230/460 VOLT TEFC, FULL LOAD AMPS 3.2/3.0/1.5.
 - MOTOR WITHOUT SWITCH: 3/4 HP 3Ø 60 HZ 575 VOLT TEFC, FULL LOAD AMPS 1.2.
 - MOTOR WITHOUT SWITCH: 3/4 HP 3Ø 50 HZ 220/380/440 VOLT TEFC, FULL LOAD AMPS 2.8/1.6/1.4.

4 INCH FAN TRANSITION

		DIVISION OF A.T.FERRELL COMPANY 1440 S ADAMS ST BLUFFTON, INDIANA 46714 - USA PH: 260-824-3400 FAX: 260-824-5463		This drawing is the property of the A. T. Ferrell Company, Inc and must be returned immediately upon request. No part of this drawing may be reproduced, stored in a retrieval system or transmitted in any form or by any means, without prior written consent of the A. T. Ferrell Company, Inc.	
TOLERANCES EXCEPT AS NOTED DECIMAL: XX ± .030 XXX ± .005 XXXX ± .001		FRACTIONAL: ± 1/32 ANGULAR: ± 1/2°		TITLE: CLEANER ASSY, RH & CENTER, AGM224 FINISH: NONE	
CAD NO MANUAL CHANGES		SCALE: 1:10	SHEET: 6 OF 7	SIZE: D	PART NUMBER: F6000200-I
				DRAWN BY: samelching	DRAWN DATE: 4/25/2012
				APPROVED BY: DMJ	REV: E