

REVISION HISTORY				
REV	FCN	DESCRIPTION	DATE	APPROVED
A	K990047	RELEASED	7/9/1999	AP
B	K080188	REDRAWN IN INVENTOR, WAS GROUP DRAWING, D-SIZE	11/4/2008	pggalicia

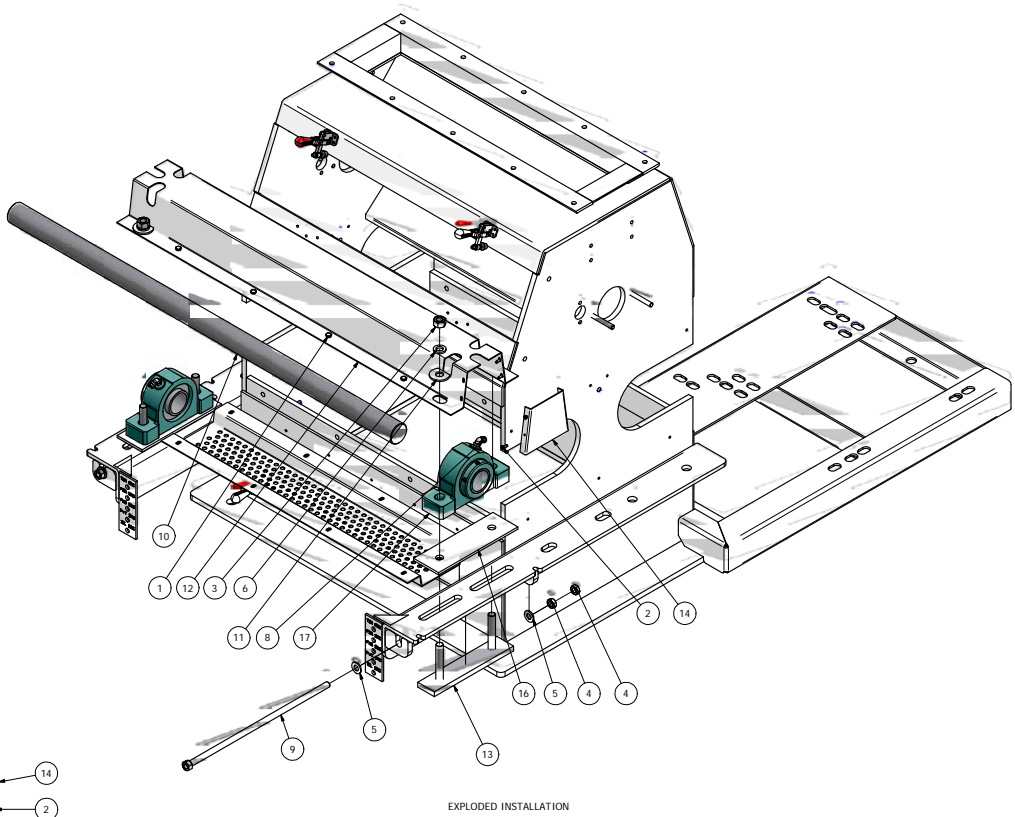
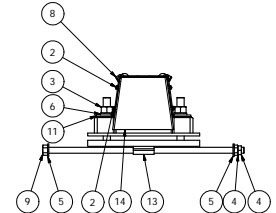
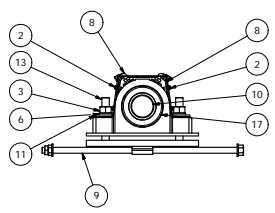
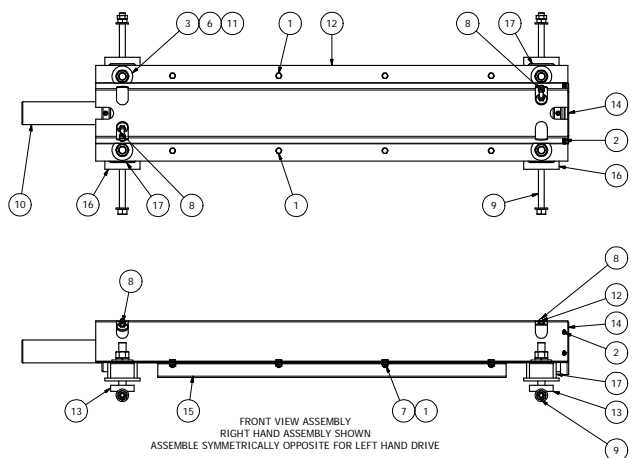
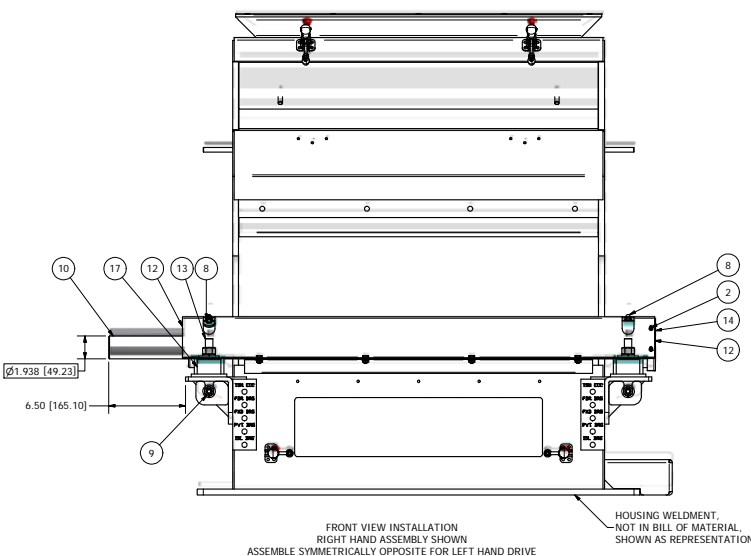

EXPLODED INSTALLATION

ITEM	PART NUMBER	QTY	DESCRIPTION
17	K902-11301	2	BRNG, PB 2 HOLE 1.938"
16	K200-10884	2	SPACER, IDLER BEARING, 10/12/18"
15	K200-10656	1	GUARD, BOTTOM, DIFF IDLER, 10 X 30"
14	K200-10655	1	END, GUARD, IDLER SHAFT 10/12"
13	K200-10580	2	SLIDE WLDMT, IDLER BEARING, 10-12"
12	K200-01674	1	GUARD, DIFF SHAFT, 10 X 30"
11	K200-01670	4	WASHER, FLAT SHEARED 5/8"
10	K200-00094	1	SHAFT, DIFFERENTIAL IDLER, 10 X 30"
9	K100-01413	2	SCREW WLDMT, IDLER BEARING, XHD 18"
8	70012050	2	CPLG, ELBOW 90 1/8-27M NPT X 1/4" TBG
7	66783300	8	NUT, HEX SERR LOCK 1/4-20
6	66445800	4	WASHER, LOCK HELICAL 5/8"
5	66405200	4	WASHER, FLAT 1/2" TYPE A
4	66105200	4	NUT, HEX JAM 1/2-13
3	66085800	4	NUT, HEX 5/8-11
2	65482212	4	SCW, MACH 8-32 X 1/2" HK SLT HD T/C
1	62583312	8	HHCS, 1/4-20 X 1/2"

- NOTES:
- DO NOT SCALE FROM DRAWING.
 - ALTERNATIVE UNITS [X.XX] IN MILLIMETERS.
 - TWO PIECES REQUIRED PER K000-01095: ROLLER MILL ASSY, 2 HI RH, STD, 10 X 30".
 - ONE PIECE REQUIRED PER K000-01102: ROLLER MILL ASSY, SINGLE HIGH, RH RF 1.0:1-1.5:1 10 X 30"
 - ONE PIECE REQUIRED PER K000-01233: ROLLER MILL ASSY, SINGLE HIGH, RH STD, 10 X 30"
 - ONE PIECE REQUIRED PER K000-01239: ROLLER MILL ASSY, SINGLE HIGH, RH, STD, 10 X 30"
 - TWO PIECES REQUIRED PER K000-01259: ROLLER MILL ASSY, 2 HI, LH, STD, 10 X 30"
 - THREE PIECES REQUIRED PER K000-02211: ROLLER MILL ASSY, 3HI RH, RF, 10 X 30"

This drawing is the property of the A.T. Ferrell Company, Inc and must be returned immediately upon request. No part of this drawing may be reproduced, stored in a retrieval system or transmitted in any form or by any means, without prior written consent of the A.T. Ferrell Company, Inc.

CAD NO MANUAL CHANGES	NO TOLERANCES EXCEPT AS NOTED	FINISH: NONE	DECIMAL: .005	ANGULAR: .1/2
DIVISION OF A.T. FERRELL COMPANY		SCALE: 0.19:1	DATE: 11/4/2008	SIZE: D
DRAWN BY: pggalicia		APPROVED BY: DMJ	PART NUMBER: K100-00453	
BLUFFTON, INDIANA, USA		IDLER ASSY, DIFFERENTIAL 1.5:1, 10 X 30"		SHEET: 1 of 1